



Hi3521D V100 H.265 CODEC Processor

Brief Data Sheet

Issue **02**

Date **2017-06-15**

Copyright © HiSilicon Technologies Co., Ltd. 2016-2017. All rights reserved.

No part of this document may be reproduced or transmitted in any form or by any means without prior written consent of HiSilicon Technologies Co., Ltd.

Trademarks and Permissions



HISILICON, and other HiSilicon icons are trademarks of HiSilicon Technologies Co., Ltd.

All other trademarks and trade names mentioned in this document are the property of their respective holders.

Notice

The purchased products, services and features are stipulated by the contract made between HiSilicon and the customer. All or part of the products, services and features described in this document may not be within the purchase scope or the usage scope. Unless otherwise specified in the contract, all statements, information, and recommendations in this document are provided "AS IS" without warranties, guarantees or representations of any kind, either express or implied.

The information in this document is subject to change without notice. Every effort has been made in the preparation of this document to ensure accuracy of the contents, but all statements, information, and recommendations in this document do not constitute a warranty of any kind, express or implied.

HiSilicon Technologies Co., Ltd.

Address: Huawei Industrial Base
Bantian, Longgang
Shenzhen 518129
People's Republic of China

Website: <http://www.hisilicon.com>

Email: support@hisilicon.com



Hi3521D V100 H.265 CODEC Processor

Key Specifications

Processor Core

- ARM Cortex A7 dual-core@maximum 1.3 GHz
 - 32 KB L1 I-cache, 32 KB L1 D-cache
 - 256 KB L2 cache
 - NEON and FPU

Video Encoding/Decoding Protocols

- H.265 Main Profile, Level 5.0 encoding
- H.265 Main Profile, Level 5.0 decoding
- H.264 Baseline/Main/High Profile, Level 5.1 encoding
- H.264 Baseline/Main/High Profile, Level 5.1 decoding
- MPEG-4 SP, L0–L3/ASP L0–L5 decoding
- MJPEG/JPEG baseline

Video Encoding/Decoding

- H.265/H.264/JPEG encoding and decoding of multiple streams
 - 4x1080p@30 fps H.265/H.264 encoding+4xD1@30 fps H.265/H.264 encoding+4x1080p@30 fps H.265/H.264 decoding+4x1080p@2 fps JPEG encoding
 - 8x720p@30 fps H.265/H.264 encoding+8xD1@30 fps H.265/H.264 encoding+8x720p@30 fps H.265/H.264 decoding+8x720p@2 fps JPEG encoding
 - 16x960H@30 fps H.265/H.264 encoding+16xCIF@30 fps H.265/H.264 encoding+16x960H@30 fps H.265/H.264 decoding+16x960H@2 fps JPEG encoding
 - 4x1080p@30 fps H.265/H.264 decoding
 - 8x720p@30 fps H.265/H.264 decoding
 - 4x1080p@30 fps JPEG decoding
- Constant bit rate (CBR) mode, variable bit rate (VBR) mode, FIXQP mode, adaptive variable bit rate (AVBR) mode, and QpMap mode
- Maximum 40 Mbit/s output bit rate
- ROI encoding
- Color-to-gray encoding

Intelligent Video Analysis

- Integrated IVE, supporting various intelligent analysis applications such as motion detection, perimeter defense, and video diagnosis

Video and Graphics Processing

- Deinterlacing, sharpening, 3D denoising, dynamic contrast improvement, and demosaic
- Anti-flicker for output videos and graphics
- 1/15x to 16x video scaling
- 1/2x to 2x graphics scaling
- Four Cover regions
- OSD overlaying of eight regions

Audio Encoding/Decoding

- ADPCM, G.711, and G.726 hardware audio encoding
- Software audio encoding and decoding complying with multiple protocols

Security Engine

- AES, DES, and 3DES algorithms implemented by hardware

Video Interfaces

- VI interfaces
 - Four 8-bit interfaces or two 16-bit interfaces
 - 108 MHz/144 MHz 4xD1/960H TDM inputs for each 8-bit interface (16xD1/16x960H real-time video inputs in total)
 - 144 MHz/148.5 MHz 2x720p TDM inputs for each 8-bit interface (8x720p@30 fps real-time video inputs in total)
 - 4x720p TDM inputs through 148.5 MHz dual-edge sampling or 297 MHz single-edge sampling for each 8-bit interface (16x720p@30 fps real-time video inputs in total)
 - 148.5 MHz BT.1120 Y/C interleaved mode for each 8-bit interface (4x1080p@30 fps real-time video inputs in total)
 - 2x1080p TDM inputs through 148.5 MHz dual-edge sampling or 297 MHz single-edge sampling for each 8-bit interface (8x1080p@30 fps real-time video inputs in total)
 - 1x4M (2560 x 1440) TDM inputs through 148.5 MHz dual-edge or 297 MHz single-edge sampling for each 8-bit interface (4x4M@30 fps real-time video inputs in total)
 - 148.5 MHz BT.1120 standard mode for the 16-bit interface (2x1080p@60 fps real-time video inputs in total)
- VO interfaces
 - One HDMI 1.4b output interface with the maximum output of 3840 x 2160@30 fps
 - One VGA HD output interface with the maximum output of 1080p@60 fps
 - Two independent HD output channels (DHD0 and DHD1), output over any HD interface (HDMI or VGA)
 - 36-picture output for DHD0, maximum output of 3840 x 2160@30 fps
 - 16-picture output for DHD1, maximum output of 1080p@60 fps
 - One CVBS SD output interface
 - Three full-screen GUI graphics layers in ARGB1555 or ARGB8888 format for two HD channels and one SD channel
 - Two hardware cursor layers in ARGB1555 or ARGB8888 format (configurable) with the maximum resolution of 256 x 256

Audio Interfaces

- Three unidirectional I²S/PCM interfaces
 - Two input interfaces, supporting 16 multiplexed inputs
 - One output, supporting dual-channel output
 - 16-bit audio inputs and outputs



Hi3521D V100 H.265 CODEC Processor

Ethernet Ports

- One gigabit Ethernet port
 - RGMII, RMII, and MII modes
 - 10/100 Mbit/s half-duplex or full-duplex
 - 1000 Mbit/s full-duplex
 - TSO for reducing the CPU usage

Peripheral Interfaces

- Two SATA 3.0 interfaces
 - PM
 - eSATA
- Two USB 2.0 host ports, supporting the hub
- Three UART interfaces, one of which supporting four wires
- One SPI, supporting two CSs
- One IR interface
- One I²C interface
- Multiple GPIO interfaces

Memory Interfaces

- One 32-bit DDR3 SDRAM interface
 - Maximum frequency of 933 MHz
 - ODT
 - Maximum capacity of 2 GB
 - Automatic power consumption control
- SPI NOR/NAND flash interface
 - 1-/2-/4-wire SPI NOR/NAND flash
 - Two CSs, connected to different types of flash memories
 - Maximum capacity of 64 MB for each CS (for the SPI NOR flash)
 - Maximum capacity of 512 MB for each CS (for the SPI NAND flash)

- 2 KB/4 KB page size (for the SPI NAND flash)
- 8-bit/1 KB or 24-bit/1 KB ECC (for the SPI NAND flash)

- Embedded 4 KB BOOTROM and 16 KB SRAM

RTC with an Independent Power Supply

- Independent battery for supplying power to the RTC

Configurable Boot Modes

- Booting from the BOOTROM
- Booting from the SPI NOR flash
- Booting from the SPI NAND flash

SDK

- Linux 3.18-based SDK
- Audio encoding and decoding libraries complying with various protocols
- High-performance H.265/H.264 PC decoding library

Physical Specifications

- Power consumption
 - Typical power consumption of 2.5W
 - Multi-level power consumption control
- Operating voltages
 - 0.9 V core voltage
 - 1.0V CPU voltage
 - 3.3 V I/O voltage
 - 1.5 V DDR3 SDRAM interface voltage
- Package
 - RoHS, TFBGA
 - Lead pitch of 0.8 mm (0.03 in.)
 - Body size of 19 mm x 19 mm (0.75 in. x 0.75 in.)
- Operating temperature ranging from 0°C (32°F) to 70°C (158°F)

Hi3521D V100 H.265 CODEC Processor

Functional Block Diagram

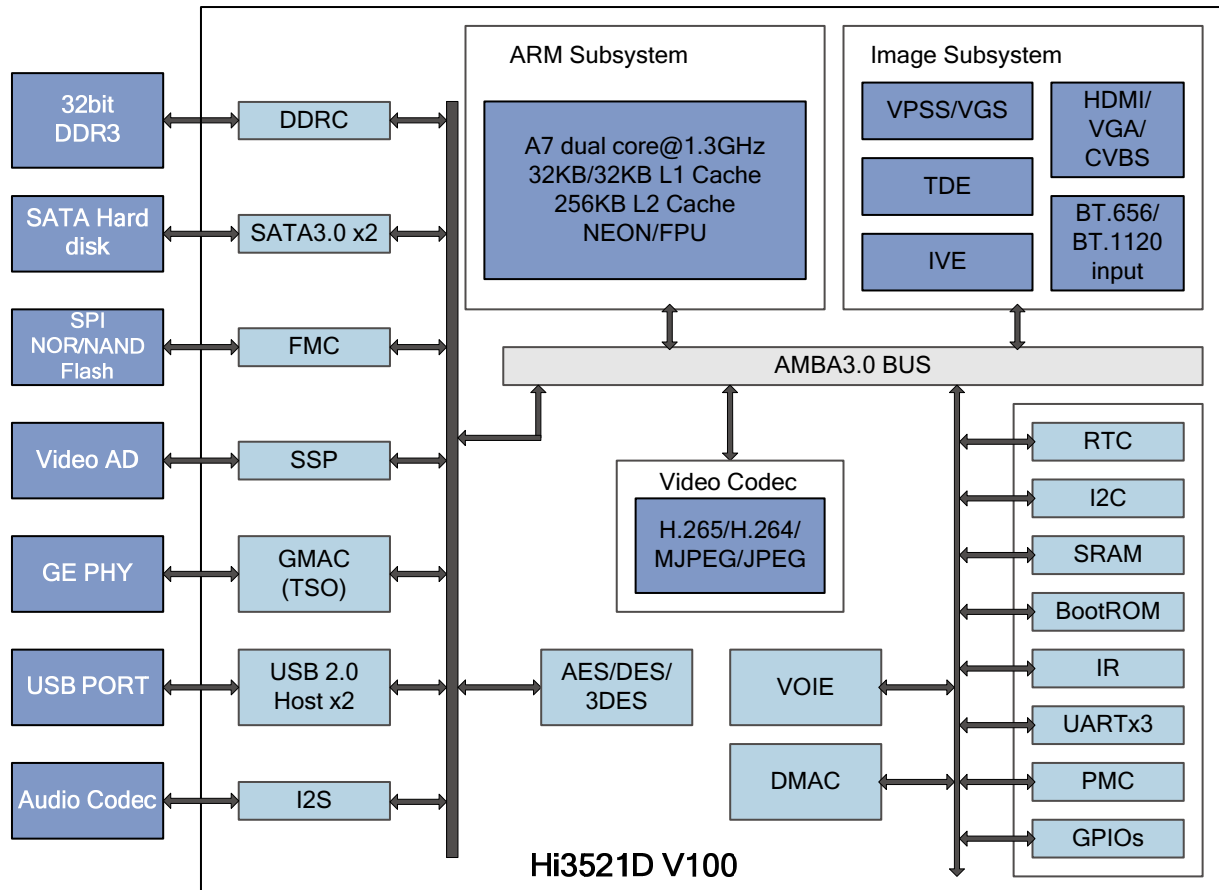

The Hi3521D V100 is a professional SoC targeted for the multi-channel HD (1080p/720p) or SD (D1/960H) DVR. The Hi3521D V100 provides an ARM A7 dual-core processor, a high-performance H.265/H.264 video encoding/decoding engine, a high-performance video/graphics processing engine with various complicated graphics processing algorithms, HDMI/VGA HD outputs, and various peripheral interfaces. These features enable the Hi3521D V100 to provide high-performance, high-picture-quality, and low-cost analog HD/SDI solutions for customers' products while reducing the eBOM cost.

DVRs (Each with a Hi3521D V100)

4x1080p DVR

- 4x1080p@30 fps H.265 encoding+4xD1@30 fps H.265 encoding+4x1080p@30 fps H.265 decoding+4x1080p@2 fps JPEG encoding
- HDMI+VGA 1080p@60 fps outputs from the same source+CVBS outputs

8x720p DVR

- 8x720p@30 fps H.265 encoding+8xD1@30 fps H.265 encoding+8x720p@30 fps H.265 decoding+8x720p@2 fps JPEG encoding
- HDMI+VGA 1080p@60 fps outputs from the same source+CVBS outputs

16x720p (Non-Real-Time)

- 16x720p@15 fps H.265 encoding+16xD1@15 fps H.265 encoding+16x720p@15 fps H.265 decoding+16x720p@2 fps JPEG



Hi3521D V100 H.265 CODEC Processor

encoding

- HDMI+VGA 1080p@60 fps outputs from the same source+CVBS outputs

16x960H DVR

- 16x960H@30 fps H.265 encoding +16xCIF@30 fps H.265 encoding+16x960H@30 fps H.265 decoding+16x960H@2 fps JPEG encoding
- HDMI+VGA 1080p@60 fps outputs from the same source+CVBS outputs

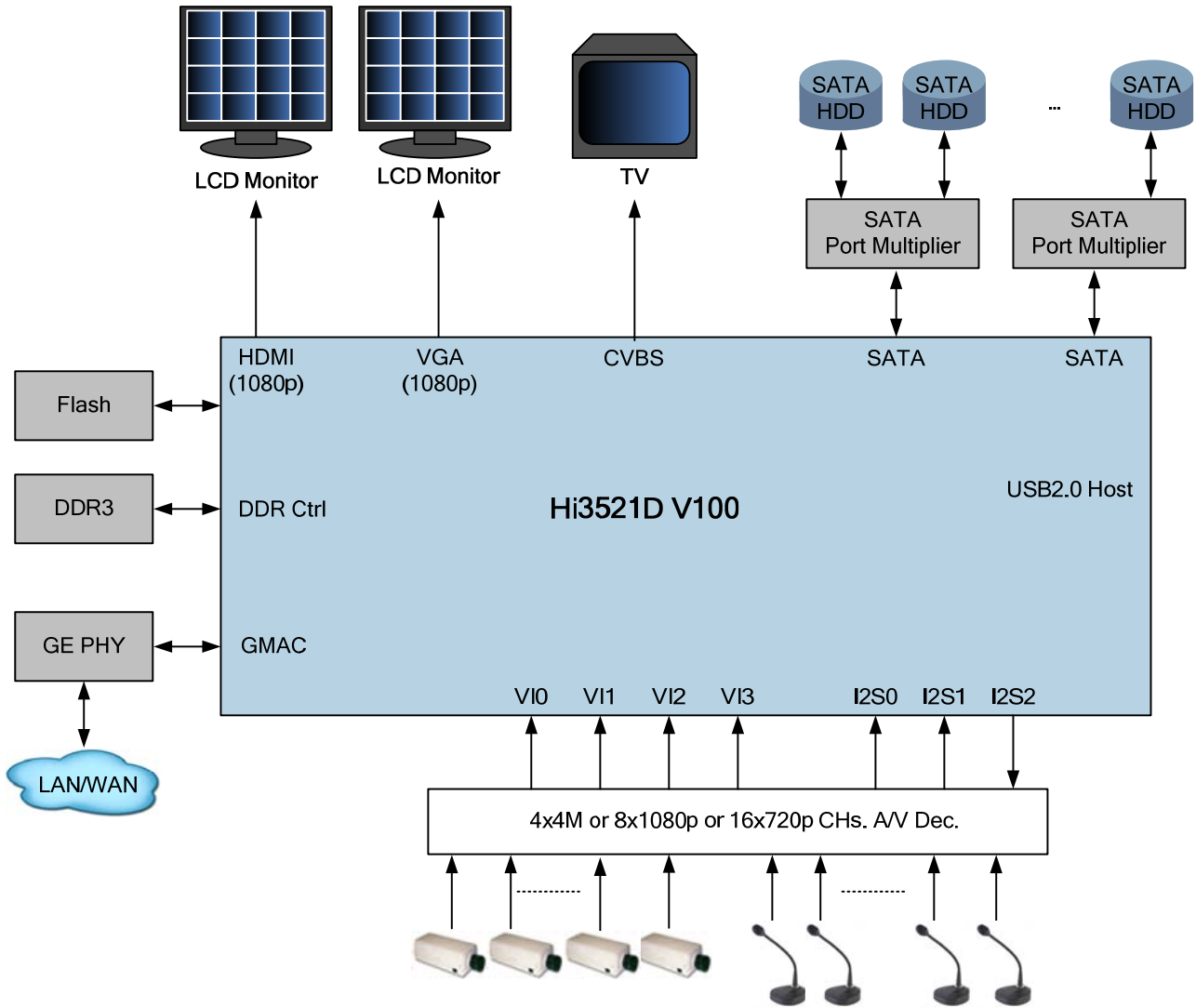



Acronyms and Abbreviations

3DES	triple data encryption standard
ADPCM	adaptive differential pulse code modulation
AES	advanced encryption standard
CBR	constant bit rate
CS	chip select
CVBS	composite video broadcast signal
DCI	dynamic contrast improvement
DDR	double data rate
DES	data encryption standard
DVR	digital video recorder
eBOM	engineering bill of materials
ECC	error correcting code
eSATA	external serial advanced technology attachment
GPIO	general-purpose input/output
HD	high definition
HDMI	high definition multimedia interface
I ² C	inter-integrated circuit
I ² S	inter-IC sound
IR	infrared
IVE	intelligent video engine
MII	media independent interface
ODT	on-die termination
OSD	on-screen display
PCM	pulse code modulation
PM	port multiplexer
QP	quantization parameter
RGMI	reduced gigabit media independent interface
RMII	reduced media independent interface
RoHS	Restriction of Hazardous Substances
ROI	region of interest
RTC	real-time clock
SATA	serial advanced technology attachment
SD	standard definition
SDI	serial digital interface
SDK	software development kit
SDRAM	synchronous dynamic random access memory
SoC	system-on-chip
SPI	serial peripheral interface
SRAM	static random access memory
TDM	time division multiplexing
TSO	TCP segmentation offload
UART	universal asynchronous receiver transmitter
VBR	variable bit rate
VGA	video graphics array
VI	video input
VO	video output

